



**CREATING VALUES
IN SEQUENCE**



DFT – Dürkopp Fördertechnik GmbH is a global leader in highly automated sorting systems for hanging and flat goods. With strong focus on e-commerce and the fashion and retail industries, DFT delivers customized solutions in distribution.

The company, located in Bielefeld (Germany) and currently employing more than 500 people, was founded in 1954 as a division of the Bielefeld based Dürkoppwerke. Since the spin-off as an independent company in 1995 and the acquisition by the KNAPP Group in 2010, DFT has established itself with high-quality overhead conveyor technology and sorting solutions and as a leading supplier in the fashion industry.

DFT provides integrated solutions and services for industries such as fashion, retail, pharmaceuticals and electronics. The innovations include the AutoPocket®, a hanging transport bag with automatic opening and closing functions, and a portfolio of flat-good sorters developed based on customer requirements. With a strong sustainability and customer centric focus, DFT is committed to long-term customer relationships and the highest quality in distribution.

120+ Brands: Over 120 well-known brands worldwide trust in the technology and expertise of DFT to manage their logistical challenges.

340+ Distribution Centers: DFT has successfully established more than 340 distribution centers worldwide, supporting the efficient storage and shipping of its customers.

Business applications

- Distribution
- Logistics automation
- Sequencing and sorting systems for warehouse distribution
- Shipping sortation for e-Commerce and store delivery
- Returns management

Industries

- Fashion
- Retail
- Wholesale
- Pharmaceuticals / Cosmetics
- Parcel & Post
- Electronics



Individual Solutions for your Sorting Requirements

Automated sorting and sequencing play a crucial role in modern material handling systems. They are used to pick goods, parcels or fashion and deliver them to various destinations for packing.

Our DFT adapter and hanging garment solutions can be used for garments on hangers or flat goods, as well as for other product categories such as medicines, beauty products, electronic items or parcels up to a certain size.

Our broad system portfolio with different degrees of automation provides the fitting solution for a wide range of requirements. The AutoPocket® offers a smart sorting solution for distribution that enables versatile solution designs for sorting and sequencing for store orders or e-commerce orders thanks to a modular basic concept. With the EcoPocket®, both hanging garments and flat folded goods can be combined in one system. The overhead conveyor systems, with a capacity of **up to 12,000 adapters per hour**, also enable the efficient integration of returns management and the rapid return of high-demand items to the ordering process. The GarmentFlow® system transports, separates and picks garments on hangers in high volumes and with high throughput – ideal for fashion distribution. The EcoFlow® adapter system offers a powerful and intelligent solution for the transportation and sequencing of hanging garments, where each adapter element can be controlled individually. The EcoTrolley is the solution for smaller applications in the transportation of hanging garments. The system can be expanded at any time and reduces manual garment movement. We can also be the single source provider of the combination of our overhead conveyor technology with conveyor technology for containers and cartons.

AutoPocket® 4

EcoPocket® 6

EcoFlow® 8

GarmentFlow® 10

EcoTrolley 12

Digital Twin 14

Condition Monitoring Center 15



PROVEN

100

TIMES

20 YEARS OF EXPERTISE.
100 ADAPTER SYSTEMS.

EXPANDABLE

SCALABLE

SPACE EFFICIENT



Perfect use of space



Manual loading



Automatic unloading



Gentle product unloading

AutoPocket®

High-Performance Sorting with optional Buffer

The innovative AutoPocket® system from DFT automates sorting and sequencing processes for a wide range of applications.

Whether inbound goods sortation, e-Commerce processing, store delivery or outbound sortation, all these processes can be performed by the AutoPocket®. With modular components, the AutoPocket® system enables flexible automation of distribution processes tailored to the application.

The option of automatic or manual loading and automatic unloading of items minimizes manual effort throughout the entire process. The ability to open and unload the AutoPocket® while moving at full speed opens up completely new possibilities for automation.

The optional dynamic buffer enhances efficiency of returns handling and enables predictive picking. These items can be loaded directly into the AutoPocket® and remain in the buffer until they are needed so that they can then be automatically merged with the rest of the order.

AT A GLANCE

Products



Automation

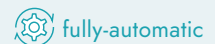

Transportation

Sorting

Sequencing

TECHNICAL DATA

Capacity	7,500–12,000 pockets/h system rate 10,000–15,000 pockets/h component rate
Max. product size	600 x 400 x 150 mm / 23.6 x 15.7 x 5.9 inches
Weight	min. 0.005 kg / 0.01 lbs max. 3 kg / 6.6 lbs
Product infeed	manual or automatic
Product discharge	automatic

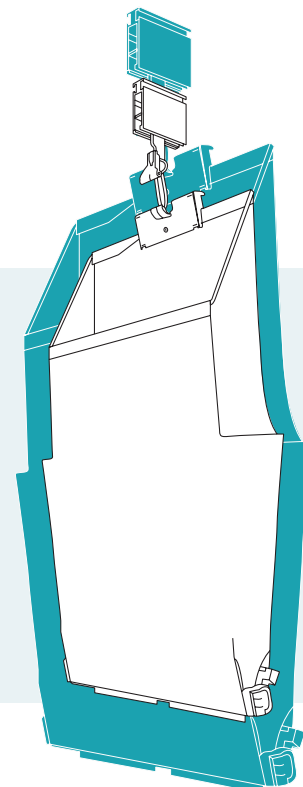

Watch the video:
www.duerkopp.com/en/autopocket-sorter



SMART

ACCURATE

MODULAR



High-volume sequencing



Manual induct



Automated induct

EcoPocket®



Scalable Sortation Solution for high Throughputs

The EcoPocket® is the perfect solution for automated and high-volume sorting and sequencing for e-commerce order processing and store replenishment. The system can be implemented as a pure pocket sorter solution in the flat-packed goods area or combined with hanging garments (Garments on Hanger/GoH).

Individual order items can be consolidated automatically and directed precisely to the respective target locations and packing stations. With the help of dynamic buffers, items can be temporarily stored and returns or fast-moving products (pre-pick) can be efficiently integrated into the ongoing process. The EcoPocket® adapts to the packing speeds of the individual workstations and automatically compensates for differences in speed to ensure a streamlined and efficient flow throughout the entire process.

The EcoPocket® system is scalable and expandable and can be precisely adapted to specific requirements and the desired degree of automation. Optional upgrades include dynamic buffers, automatic loading and automatic packaging. As a hybrid system, the EcoPocket® can also be combined with other DFT systems, such as the EcoFlow for efficient processing of hanging garments (GoH).

AT A GLANCE

- Products 
- Automation  semi-automatic
- Transportation Sorting Sequencing

TECHNICAL DATA

Capacity	7,500 – 12,000 pockets/h system rate 10,000 – 15,000 pockets/h component rate
Max. product size	500 x 380 x 150 mm / 19.7 x 15 x 5.9 inches
Weight	min. 0.005kg / 0.01lbs max. 3kg / 6.6lbs
Product infeed	manual or automatic
Product discharge	manual

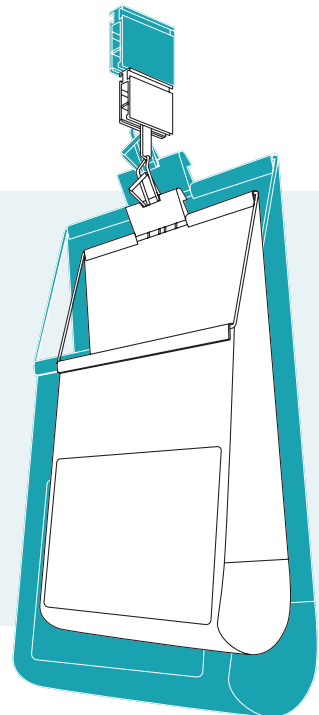

Watch the video:
www.duerkopp.com/en/ecopocket



EFFICIENT

PROVEN

FLEXIBLE



Precise individual part conveying



Adapter technology with RFID recognition

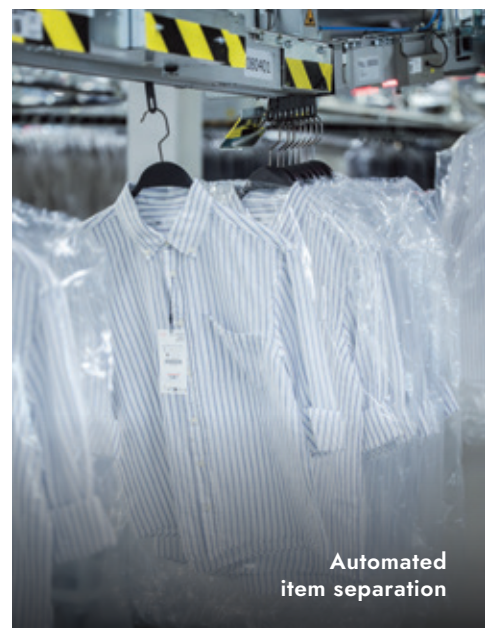

Automated item separation

EcoFlow®

Innovative Adapter Technology for conveying individual Parts

The EcoFlow® adapter technology has been designed specially for garments on hangers (GoH) and offers an advanced solution for single item conveying and sequencing.

Individual units from various storage areas can be consolidated and temporarily buffered to allow for precise sorting and sequencing at a defined point in time. The goods are transported on adapters and automatically and precisely transferred to the packaging or shipping process at the right time and in the right sequence.

Each adapter in the EcoFlow® system is equipped with an RFID chip that enables the identification, tracking and individual control of each item in the system. The individual items are hung on hangers on the roll adapter and the item data is linked to the RFID chip fully automatically. Hanging garments from manual or GarmentFlow® systems can also be automatically transferred to an adapter.

EcoFlow® can be seamlessly connected to the EcoPocket® system for effective processing of hanging and flat-packed goods in one system. This integration optimizes distribution processes and ensures smooth and efficient handling of your items.

AT A GLANCE

Products



Automation



fully-automatic

Transportation

Sorting

Sequencing

TECHNICAL DATA

Capacity	7,500 – 12,000 Adapter/h system rate 10,000 – 15,000 Adapter/h component rate
Max. product size	1,800 x 700 x 150 mm / 70.9 x 27.6 x 5.9 inches
Weight	max. 3.5 kg/adapter max. 7.7 lbs/adapter
Product infeed	manual or automatic
Product discharge	manual or automatic

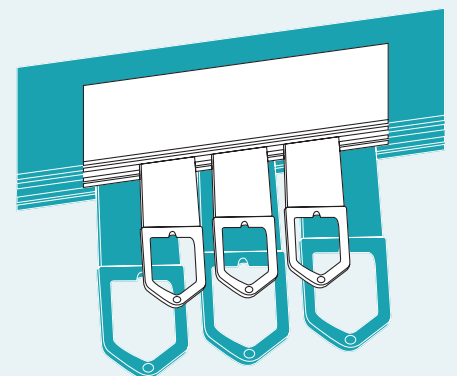

Watch the video:
www.duerkopp.com/en/ecoflow



HIGH-VOLUME

VERSATILE

RELIABLE



Gentle transportation
on hangers



Truck unloading by telescope



Safe transportation
of different hangers

GarmentFlow®

Efficient System for Hanging Goods

For more than 50 years, we have been supplying this proven hanging garment system, which has been continuously developed to meet various intralogistics challenges. The GarmentFlow® system transports, separates and picks goods on hangers (GoH) in very high volumes and high throughput.

The system shows its versatility by the fact that it can transport both individual units and blocks of goods several meters long over long distances. Our technology, which has been optimized over many years, not only offers high performance and safety, but also enables the handling of almost all hanger types. The goods are transported and sorted automatically, while buffer areas, where the goods need to remain easily movable and accessible, can be operated manually.

The GarmentFlow® system offers complete warehouse automation and can be used for transport and distribution tasks in various areas such as incoming goods, storage and retrieval, sorting and outgoing goods. By integrating RFID technology or barcodes, blocks of goods or individual items can be identified and tracked.

AT A GLANCE

Products



Automation



semi-automatic

Transportation

Sequencing

TECHNICAL DATA

Capacity	max. 40,000 parts/h block transport max. 11,000 parts/h single part transport
Max. product size	1,800 x 700 x 150 mm / 70.9 x 27.6 x 5.9 inches
Weight	max. 50 kg/m max. 110.2 lbs/m
Product infeed	manual or automatic
Product discharge	automatic

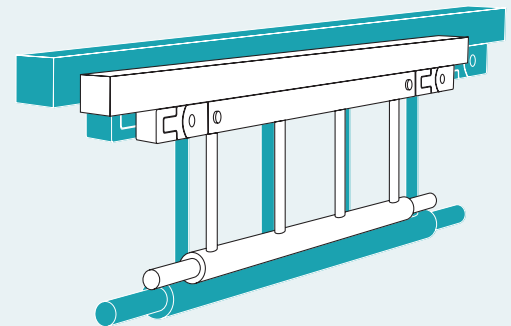

Watch the video:
www.duerkopp.com/en/garmentflow



MAINTENANCE-FREE

USER-FRIENDLY

PRICE-EFFICIENT



**Structured
warehouse logistics**

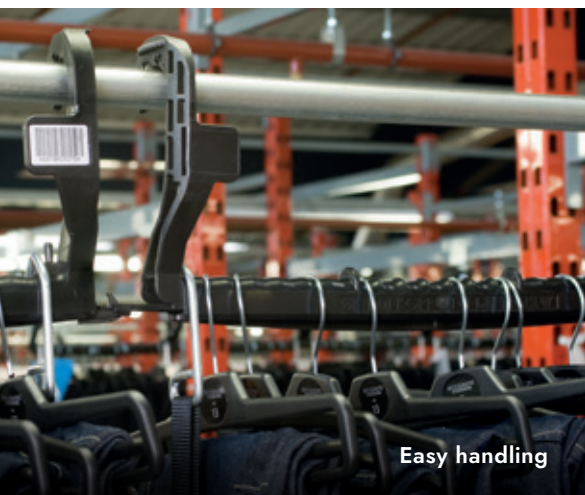

Easy handling



Durable components



**Automated
level bridging**

EcoTrolley



Manual System for maximum Efficiency

The EcoTrolley is DFT's manual conveyor system and the solution for the efficient transportation and storage of hanging garments. The garments can be moved directly on hangers or with the help of the trolleys. With a minimal investment, manual handling and walking distances can be significantly reduced.

Thanks to their low weight, the trolleys are particularly easy to handle. The trolleys can be easily removed from the system and linked together for the transportation of large quantities of items and conveyed as a unit. Optional integration of RFID chips or barcodes on the trolleys allows goods to be tracked and identified throughout the entire system.

Depending on the requirements, the system can be optionally extended with additional components. By integrating a brake and drag chain, multiple levels of the system can be reached automatically. In the inbound and outbound areas, flexible loading rails can be hooked into the trucks or containers to make all processes in these areas more efficient.

AT A GLANCE

- Products 
- Automation  manual
- Transportation

TECHNICAL DATA

Capacity	Depending on the quantity and load of trolleys and operators
Max. product size	1,800 x 700 x 300 mm / 70.9 x 27.6 x 11.8 inches
Weight	max. 20 kg/trolley max. 44.1 lbs/trolley
Product infeed	manual
Product discharge	manual

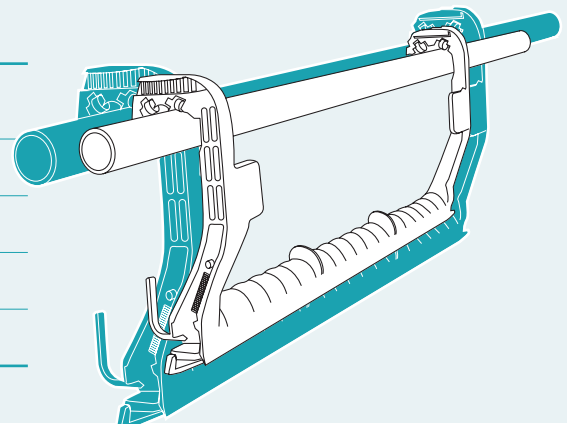

Watch the video:
www.duerkopp.com/en/eco-trolley



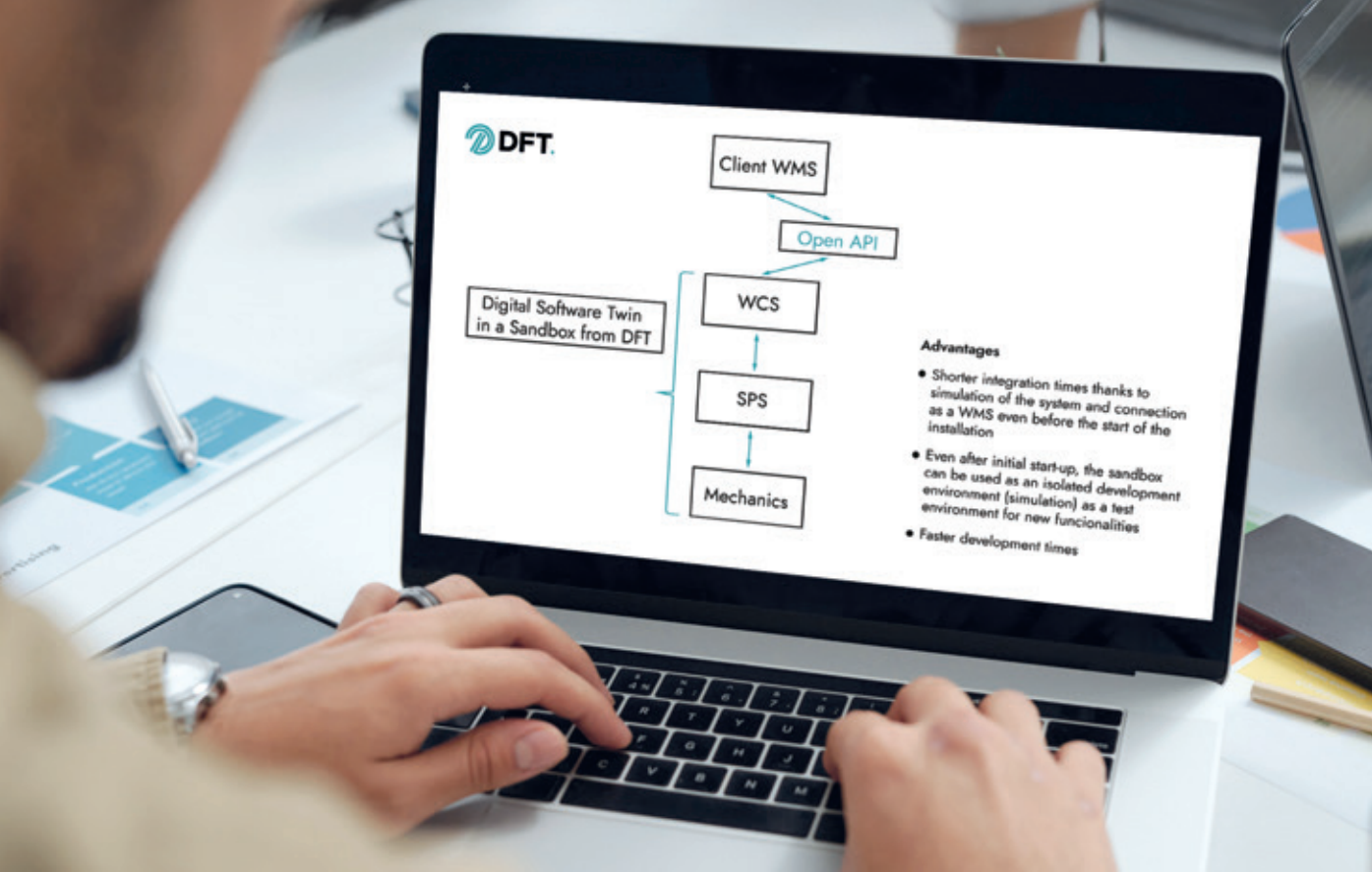

Digital Twin

Connection of the System to your WMS even before Installation

With a digital twin, we offer system operators a sandbox software solution that makes it possible to simulate the entire flow of goods and the ordering processes of the systems.

Our customers can connect their warehouse management system (WMS) to the digital twin even before the hardware is physically installed. This enables an early test phase in which errors in logistical processes can be mapped with the digital twin. Valuable time is saved as many tests and adjustments for the system are already carried out in advance. This significantly reduces the duration of the actual integration phase.

Optimization potential, such as bottlenecks in the material flow under load, can be identified and exploited in the digital environment. This minimizes rework and downtime. Changes and adjustments to the system can be tested quickly and easily in the sandbox without the need for physical components.

After the system goes live, the digital twin continues to serve as a software development environment. This means that planned WMS changes, such as extensions, can be simulated in advance in the integration environment.

Application examples

Testing order processes: Customers can run through various scenarios to see how the system reacts to different order quantities and types.
Optimize the flow of goods: By simulating the flow of goods, bottlenecks and inefficient processes can be identified and optimized.

Our digital twin offers a comprehensive and flexible way to optimize your processes and increase the efficiency of the system before the physical installation is completed.

Condition Monitoring Center

Intelligent System Monitoring for maximum operational Safety

The DFT Condition Monitoring Center offers intelligent system monitoring enabling maximum operational reliability and continuous improvement of production processes. By automatically recording and analyzing detailed system data, performance fluctuations and impending faults are detected at an early stage. This extends the life of the systems and reduces unplanned downtime.

Modern production systems generate a large amount of data that provides valuable insights into their condition and performance. Our experts use this data in a targeted manner to initiate proactive measures and

avoid critical system failures. By comparing actual data with target values, deviations can be identified and preventative measures initiated. This optimizes maintenance processes and maximizes system availability in the long term.

You can select one of our individual service models that fits your specific needs. You can choose between a flexible service model without a fixed contract or a comprehensive model with a support desk contract and active management by our experts. This enables efficient and cost-saving use of our analysis and services, tailored to your requirements.

Find out more at:
www.duerkopp.com/en/solutions/dft-condition-monitoring-center





Dürkopp Fördertechnik GmbH
Potsdamer Straße 190
33719 Bielefeld
Germany



Your contact:

Thomas Blattner

Head of Sales Overhead Technologies

T +49 (0)521 922 76 846

M +49 (0)172 52 32 016

Thomas.Blattner@duerkopp.com